

SFP28-25G-ER

28Gb/s 1310nm SFP28 40km Transceiver

Product Features

- Supports 24.3Gb/s to 26.5Gb/s bit rates
- Up to 40km transmission on SMF
- EML TOSA and APD receiver
- Metal enclosure, for lower EMI
- 2-wire interface with integrated Digital Diagnostic monitoring
- Specifications compliant with SFF 8472
- Compliant with SFP28 MSA with LC connector
- Single 3.3V power supply
- Power dissipation < 1.8 W
- Case operating temperature range: Commercial: 0°C to +70°C
Industrial: -40°C to +85°C

Applications

- 25G Ethernet
- CPRI 10

Standard

- Compliant to SFF-8431
- Compliant to SFF 8472
- Compliant to IEEE 802.3 CC
- RoHS Compliant.

Absolute Maximum Ratings

Parameter	Symbol	Min.	Typ.	Max.	Unit	Note
Storage Temperature	Ts	-40	-	85	°C	
Relative Humidity	RH	5	-	95	%	
Power Supply Voltage	VCC	-0.3	-	4	V	

Recommended Operating Conditions

Parameter	Symbol	Min.	Typ.	Max.	Unit	Note
Case Operating Temperature	Tcase	0		70	°C	Commercial
		-40		85	°C	Industrial
Power Supply Voltage	VCC	3.14	3.3	3.47	V	
Power Supply Current	ICC	-		500	mA	Commercial
				550	mA	Industrial
Data Rate	BR	24.3	25.78	26.5	Gbps	
Transmission Distance	TD		-	40	km	
Coupled fiber	Single mode fiber					9/125um SMF

Optical Characteristics

Parameter	Symbol	Min	Typ	Max	Unit	NOTE
Transmitter						
Output Opt. Power	P _{OUT}	-1.6		6	dBm	1
Optical Wavelength	λ	1295		1310	nm	
Spectral Width (-20dB)	σ			1	nm	
Side-mode suppression ratio	SMSR	30			dB	
Optical Extinction Ratio	ER	4			dB	
Power off Tx disable	P _{OFF}			-30	dBm	1
Transmitter reflection				-12	dB	
RIN (OMA)				-130	dB/Hz	
Transmitter eye mask	{0.31,0.4,0.45,0.34,0.38,0.4}					
Receiver						
Rx Sensitivity				-19.6	dBm	2
Input Saturation Power (Overload)	Psat	-5			dBm	
Receiver reflection				-26	dBm	
Wavelength Range	λ _c	1295		1325	nm	
LOS De -Assert	LOSD			-20	dBm	

LOS Assert	LOSA	-35			dBm	
LOS Hysteresis		0.5			dB	

Notes:

1. Class 1 Laser Safety per FDA/CDRH and IEC-825-1 regulations.
2. Measured with a PRBS 2³¹ -1 test pattern, @25.78Gb/s, BER@5*10⁻⁵.

Electrical Characteristics

Parameter	Symbol	Min	Typ	Max	Unit	NOTE
Supply Voltage	Vcc	3.14	3.3	3.46	V	
Supply Current	Icc			500	mA	Commercial
				550	mA	Industrial
Transmitter						
Input differential impedance	Rin		100		Ω	1
Single ended data input swing	Vin,pp	180		700	mV	
Transmit Disable Voltage	VD	2.0		Vcc+0.3	V	
Transmit Enable Voltage	VEN	-0.3		0.8	V	2
Receiver						
Differential data output swing	Vout,pp	500		900	mV	3
LOS Fault	VLOS fault	2.4		Vcc+0.3	V	4
LOS Normal	VLOS norm	-0.3		0.4	V	4

Notes:

1. Connected directly to TX data input pins. AC coupled thereafter.
2. Or open circuit.
3. Into 100 ohms differential termination.
4. Loss Of Signal is LVTTTL. Logic 0 indicates normal operation; logic 1 indicates no signal detected.

Pin Assignment

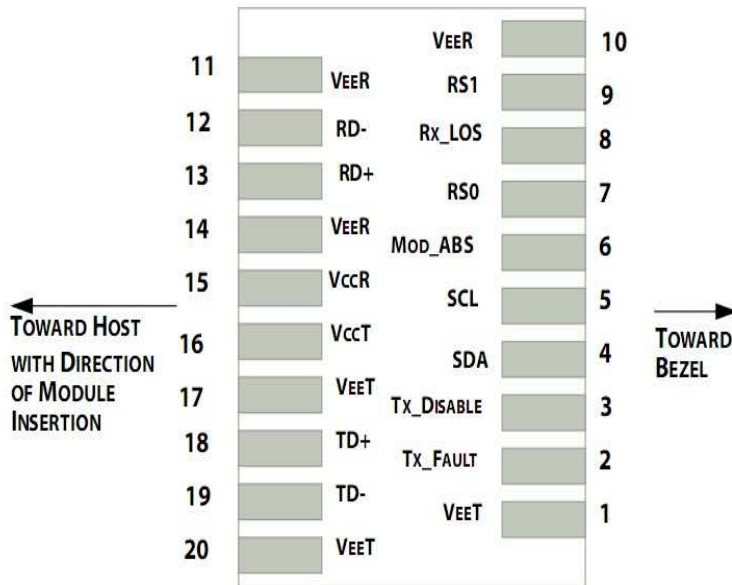

Pin out of Connector Block on Host Board

Pin	Symbol	Name/Description	NOTE
1	VeeT	Transmitter Ground (Common with Receiver Ground)	1
2	TX Fault	Transmitter Fault.	2
3	TX Disable	Transmitter Disable. Laser output disabled on high or open.	3
4	SDA	2-wire Serial Interface Data Line	4
5	SCL	2-wire Serial Interface Clock Line	4
6	MOD_ABS	Module Absent. Grounded within the module	4
7	RS0	Rate Select 0	5
8	LOS	Loss of Signal indication. Logic 0 indicates normal operation.	6
9	RS1	No connection required	1
10	VeeR	Receiver Ground (Common with Transmitter Ground)	1
11	VeeR	Receiver Ground (Common with Transmitter Ground)	1
12	RD-	Receiver Inverted DATA out. AC Coupled	
13	RD+	Receiver Non-inverted DATA out. AC Coupled	
14	VeeR	Receiver Ground (Common with Transmitter Ground)	1
15	VccR	Receiver Power Supply	
16	VccT	Transmitter Power Supply	
17	VeeT	Transmitter Ground (Common with Receiver Ground)	1
18	TD+	Transmitter Non-Inverted DATA in. AC Coupled.	
19	TD-	Transmitter Inverted DATA in. AC Coupled.	
20	VeeT	Transmitter Ground (Common with Receiver Ground)	1

Notes:

1. Circuit ground is internally isolated from chassis ground.
2. TX Fault is an open collector/drain output, which should be pulled up with a 4.7k – 10k Ohms resistor on the host board if intended for use. Pull up voltage should be between 2.0V to Vcc + 0.3V. A high output indicates a transmitter fault caused by either the TX bias current or the TX output power exceeding the preset alarm threshold. A low output indicates normal operation. In the low state, the output is pulled to <0.8V.

3. Laser output disabled on TX Disable >2.0V or open, enabled on TX Disable <0.8V. Should be pulled up with 4.7k Ω - 10k Ω host board to a voltage between 2.0V and 3.6V. MOD_ABS pulls line low to indicate module is plugged in.
4. Internally pulled down per SFF-8431 Rev 4.1.
5. LOS is open collector output. It should be pulled up with 4.7k Ω – 10k Ω on host board to a voltage between 2.0V and 3.6V. Logic 0 indicates normal operation; logic 1 indicates loss of signal.

Digital Diagnostic Functions

SFP28-25G-ER transceivers support the 2-wire serial communication protocol as defined in the SFP28 MSA. The standard SFP serial ID provides access to identification information that describes the transceiver's capabilities, standard interfaces, manufacturer, and other information.

Additionally, SFP28 transceivers provide a unique enhanced digital diagnostic monitoring interface, which allows real-time access to device operating parameters such as transceiver temperature, laser bias current, transmitted optical power, received optical power and transceiver supply voltage. It also defines a sophisticated system of alarm and warning flags, which alerts end-users when particular operating parameters are outside of a factory set normal range.

The SFP MSA defines a 256-byte memory map in EEPROM that is accessible over a 2-wire serial interface at the 8 bit address 1010000X (A0h). The digital diagnostic monitoring interface makes use of the 8 bit address 1010001X (A2h), so the originally defined serial ID memory map remains unchanged.

The operating and diagnostics information is monitored and reported by a Digital Diagnostics Transceiver Controller (DDTC) inside the transceiver, which is accessed through a 2-wire serial interface. When the serial protocol is activated, the serial clock signal (SCL, Mod Def 1) is generated by the host. The positive edge clocks data into the SFP transceiver into those segments of the E2PROM that are not write-protected. The negative edge clocks data from the SFP transceiver. The serial data signal (SDA, Mod Def 2) is bi-directional for serial data transfer. The host uses SDA in conjunction with SCL to mark the start and end of serial protocol activation. The memories are organized as a series of 8-bit data words that can be addressed individually or sequentially.

Host - Transceiver Interface Block Diagram

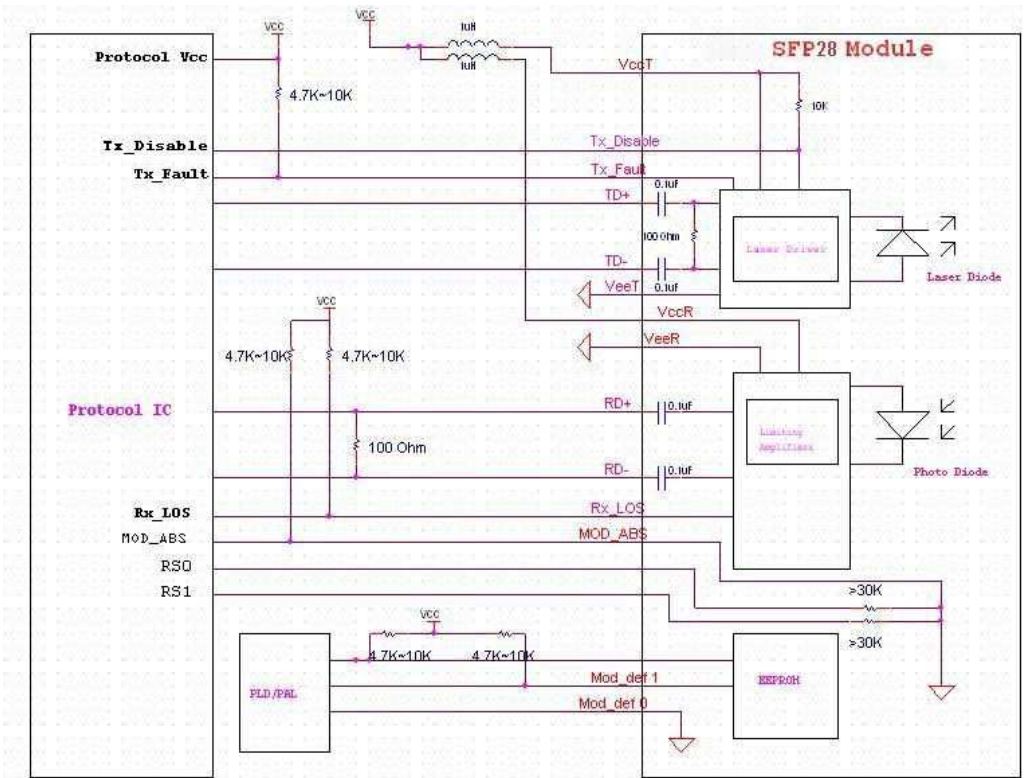

Outline Dimensions

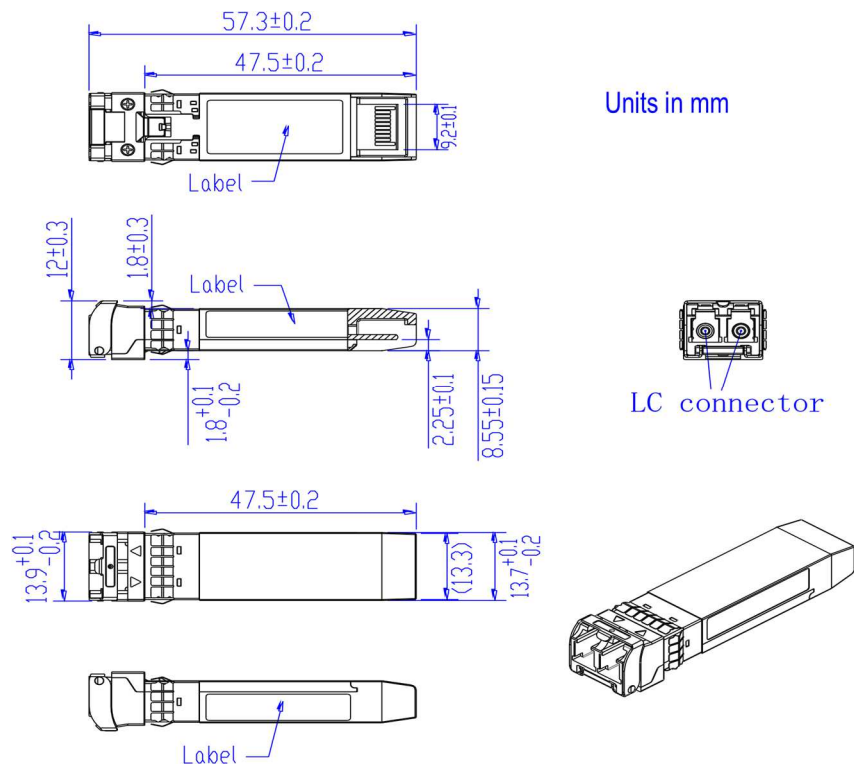

Ordering information

Part Number	Product Description
SFP28-25G-ER	1310nm, 25Gbps, LC, SMF 40km, 0°C~+70°C, With DDM
SFP28-25G-ERI	1310nm, 25Gbps, LC, SMF 40km, -40°C~+85°C, With DDM

Important Notice

Performance figures, data and any illustrative material provided in this data sheet are typical and must be specifically confirmed in writing by OPTONE before they become applicable to any particular order or contract. In accordance with the OPTONE policy of continuous improvement specifications may change without notice.

The publication of information in this data sheet does not imply freedom from patent or other protective rights of OPTONE or others. Further details are available from any OPTONE sales representative.

sales@optone.net

<http://www.optone.net>